

Backlit Serial LCD Assembly and Hookup

LCD5 version 1.4

Manual Version 1.2

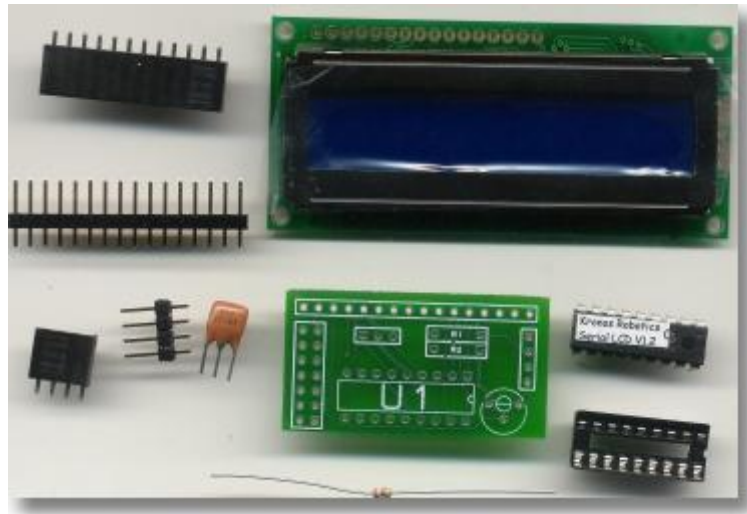

Your Kit will include the following parts

- Printed Circuit Board
- Assembly and Hookup Manual
- 18 pin Socket
- 20 Mhz Resonator
- 4 pin Straight Male Header
- 4 pin Female Header
- 12 pin Female Header
- 39 Ohm Resistor
- 16 pin male Header
- Backlit 16x2 LCD

*Kronos Robotics
and Electronics*



© Copyright 2002
Kronos Robotics

www.kronosrobotics.com
msimpson@kronosrobotics.com

Table of Contents

Features.....	4
Assembly.....	5
Hookup.....	8
Smart Module Code Examples	9
Atom and Basic Stamp Code Examples.....	10
Command Syntax.....	11
Programming the Serial LCD	15
Links	16

Features

- Accepts all LCD commands
- Speeds supported: 1200,2400,9600,19200,38400,57600,115200 at 8bit no parity
- Start up message and delay are fully programmable and saved into nonvolatile memory
- Very fast, No pacing characters or flow control needed.
- Uses only 1 pin for communications
- Has forced programmed mode for EEPROM setup
- Various Enclosures available
- Interrupt driven 64 byte buffer
- Total Splash Screen Control
- Very small piggy back profile.
- Debug (HEX output) mode
- Serviceable and upgradeable.

Very small form factor piggy back design allows the LCD to be installed in many turnkey applications.

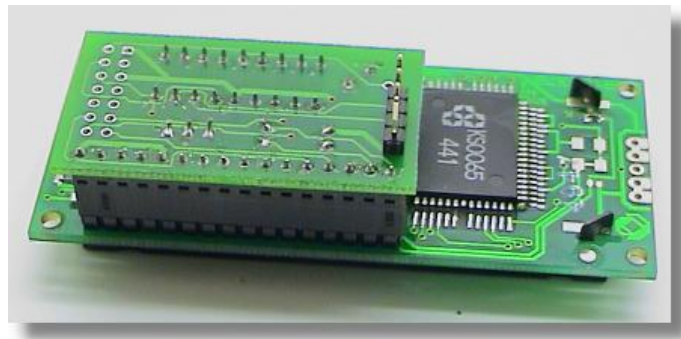

LCD separates from main circuit board for easy service and upgrades.

LCD can be serviced and upgraded while still attached to enclosure.

Assembly

If you purchased your Serial LCD already assembled disregard this section.

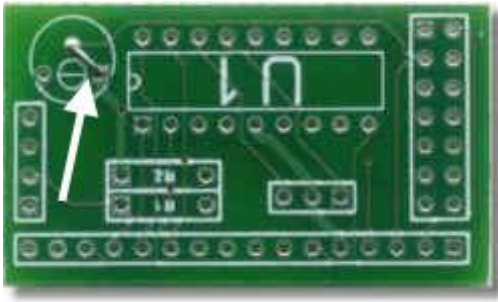

Step 1

Start by clipping about 1/2" off one of the 39 ohm resistor leads.

Insert the jumper as shown.

Solder in place and clip off excess leads

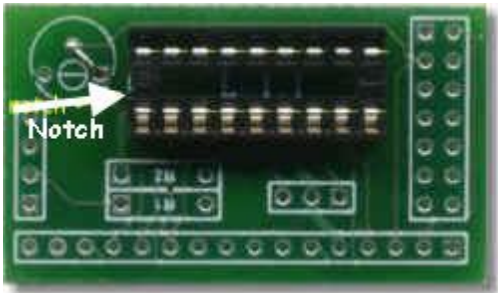

Step 2a

Install the 18 pin socket as shown.

Make sure the notch is facing the wire jumper you just installed.



Step 2b

Solder the socket in place.

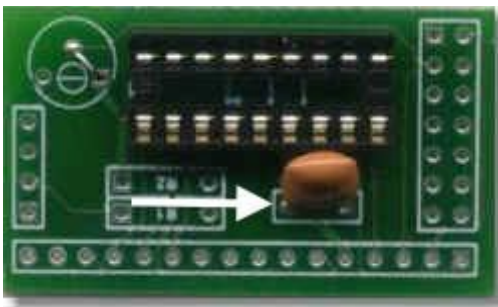

Step 3

Insert the 3 pin resonator as shown.

It does not matter which direction it is facing.

Solder in place and clip excess leads.

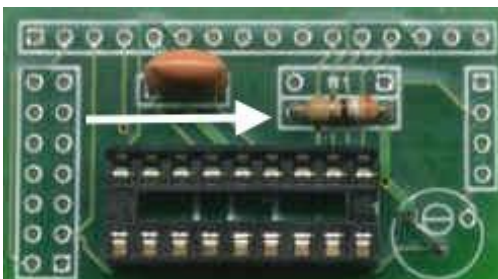

Step 4

Now insert the 39 ohm resistor into the R2 position as shown.

Solder in place and clip the excess leads.

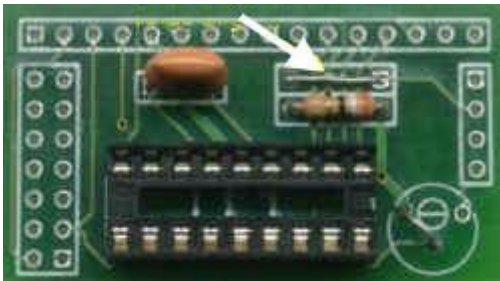

Step 5

Insert the longest clipped lead from the resistor and insert it into the R1 Position as shown. Solder in place and clip the excess leads.

Using your finger nail raise the jumper slightly so that it does not come in contact with the 4 traces the run under it. The traces have a insulated mask so this is just a precaution.



Step 6

Insert the header combo into the circuit board. Make sure the end indicated is what you insert into the circuit board. It's the end that has the 12 and 4 pin female header.

Leave the header combo connected and solder in place.

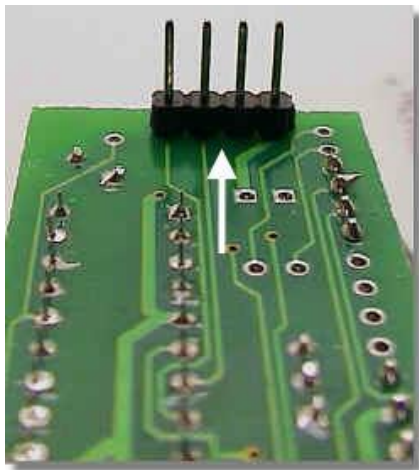
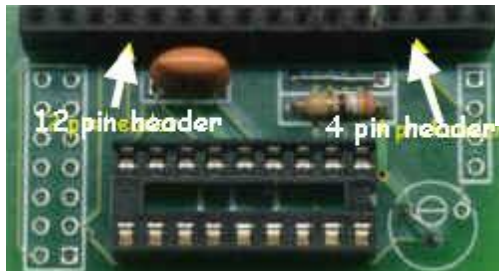

Step 7a

Now take the 4 pin straight header and insert it from the bottom of the circuit board as shown.

The short end should be what protrudes through the holes.

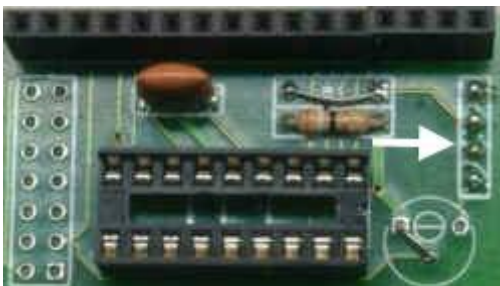

Step 7b

Solder the pins on the top site of the board as shown.

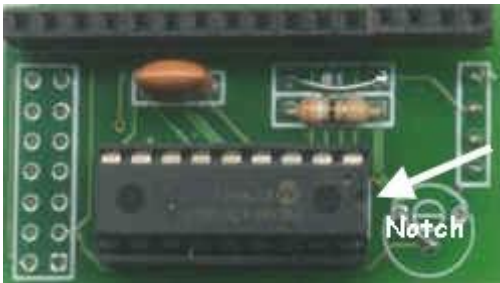

Step 8

Insert the programmed chip as shown. The notch should be facing the first jumper that you installed.

Step 9

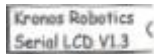

Attach the included version sticker if it has not already been attached.

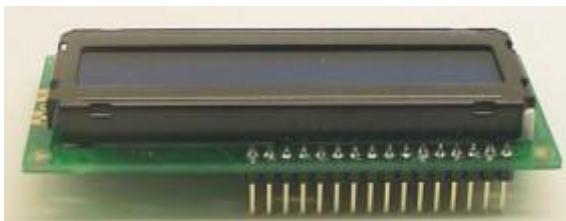

Step 10

Connect the 16 pin header as shown. The weight of the LCD will hold the header in place.

Solder as shown. Try not to over heat the pins.



Tip

You can solder the LCD in place by first inserting the 16 pin header (long pins first) into the female header. Then insert the LCD into the short pins of the header and solder in place.

Note: If you left the 16 pin header inserted into the female header when you installed it in step 6 you are good to go. Just solder the LCD to the other end of the header.

Hookup

Pins 1 and 2 provide power to the Serial LCD. Pin 3 is your serial input pin.

The input to the Serial LCD is inverted. Make sure you choose this option on your microcontroller. Most hardware UARTS use this mode.

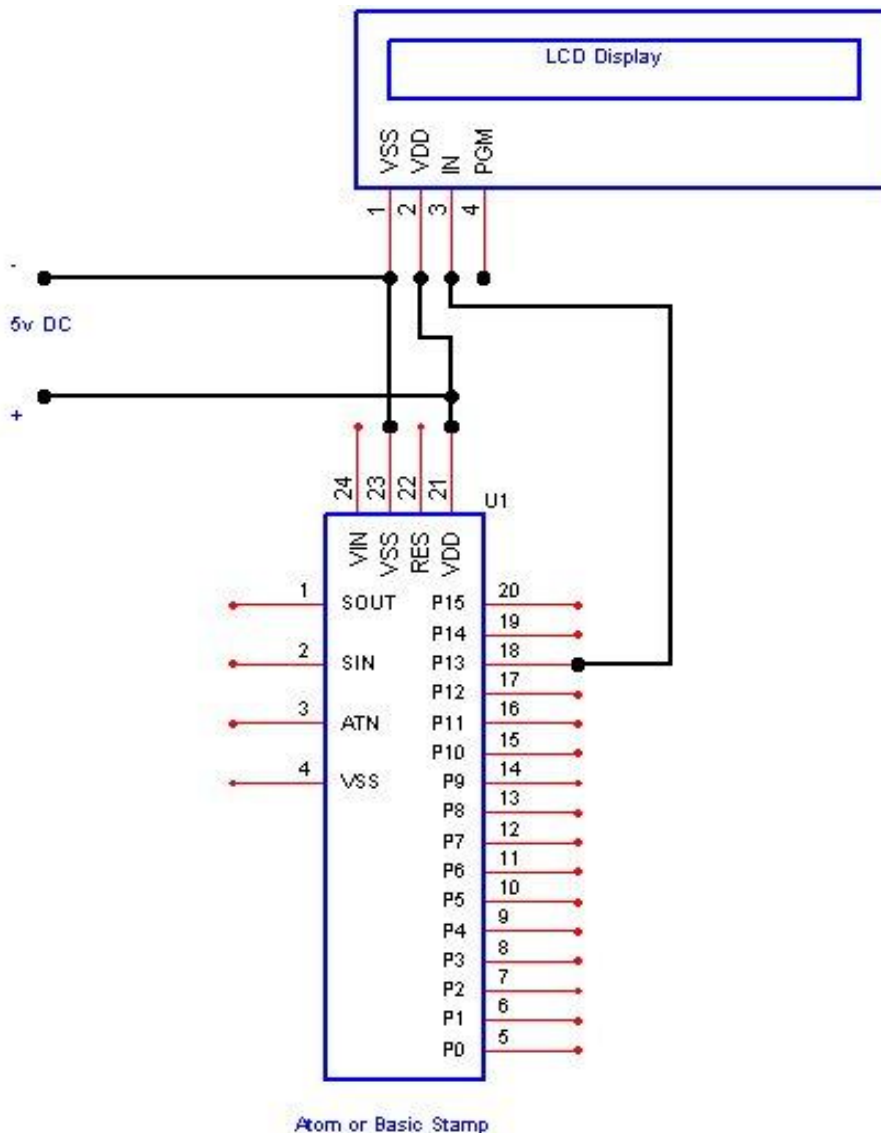
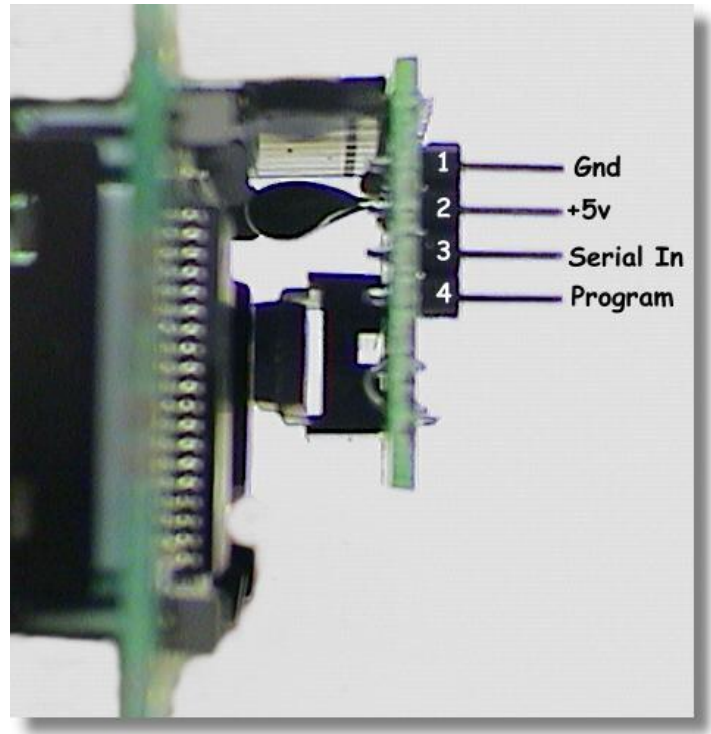

While there are many ways to connect your serial LCD to your controller this one works the best.

Warning

Never connect a PC directly to any Serial LCD. Even using current limiting resistors will lessen the life span of the LCD. The best way is to use a driver such as the Easy RS232.

I sell an Easy RS232 module on the Kronos Robotics web site. It is the cheapest and easiest way to connect your Serial LCD directly to your PC.

Part number is EZ232B

Smart Module Code Examples

Serial output via Software

Basic Text

```
serout 8,"Hello World"
```

LCD Direct

```
serout 8,3,xxx ' Where xxxx is the raw lcd data to send
```

```
serout 8,3,1 ' Clears the LCD
```

LCD Short-cuts

```
serout 8,1,1,"Now is the time" ' Displays "Now is the time" at line 1 position 1
```

```
serout 8,2,1,"For all good men" ' Displays "For all good men" at line 2 position 1
```

Serial output via Hardware serial port

Basic Text

```
hserout "Hello World" or print "Hello world";
```

LCD Direct

```
hserout 3,xxx ' Where xxxx is the raw lcd data to send
```

```
hserout 3,1 ' Clears the LCD
```

LCD Short-cuts

```
hserout 1,1,"Now is the time" ' Displays "Now is the time" at line 1 position 1
```

```
hserout 2,1,"For all good men" ' Displays "For all good men" at line 2 position 1
```

Atom and Basic Stamp Code Examples

Atom

Basic Text

```
Serout 13,i9600,["Hello World"]
```

LCD Direct

```
Serlout 13,i9600,[3,xxx] ' Where xxxx is the raw lcd data to send
```

```
Serout 13,i9600,[3,1] ' Clears the LCD
```

LCD Short-cuts

```
Serout 13,i9600,[1,1,"Now is the time"] ' Displays "Now is the time" at line 1 position 1
```

```
Serout 13,i9600,[2,1,"For all good men"] ' Displays "For all good men" at line 2 position 1
```

Basic Stamp

Basic Text

```
Serout 2,84,["Hello World"]
```

LCD Direct

```
Serlout 2,84,[3,xxx] ' Where xxxx is the raw lcd data to send
```

```
Serout 13,84,[3,1] ' Clears the LCD
```

LCD Short-cuts

```
Serout 2,84,[1,1,"Now is the time"] ' Displays "Now is the time" at line 1 position 1
```

```
Serout 2,84,[2,1,"For all good men"] ' Displays "For all good men" at line 2 position 1
```

Serial LCD Command Syntax

Byte 1	Byte 2	Description
1	X	<p>Sets the character position on line 1 to position x.</p> <p>Examples:</p> <p>SmartModule</p> <pre>serout 13,1,8,"Hello" or hserout 1,8,"Hello"</pre> <p>Atom</p> <pre>serout 13,i9600,[1,8,"Hello"]</pre> <p>Stamp</p> <pre>serout 13,84,[1,8,"Hello"]</pre> <p>Display's the word "Hello" at position 8 on line 1</p>
2	X	<p>Sets the character position on line 2 to position X.</p> <p>Examples:</p> <p>SmartModule</p> <pre>serout 13,2,1,"Hello" or hserout 2,1,"Hello"</pre> <p>Atom</p> <pre>serout 13,i9600,[2,1,"Hello"]</pre> <p>Stamp</p> <pre>serout 13,84,[2,1,"Hello"]</pre> <p>Display's the word "Hello" at position 1 on line 2</p>

3	X	<p>This command lets you output raw LCD commands X. You need to look at the LCD controller chip spec for these. Here are a few examples. Also check out the demo code for more examples.</p> <p>3,1 Clear the display</p> <p>3,2 Home the display</p> <p>3,28 Shift text to the right</p> <p>3,24 Shift text to the left</p> <p>3,64 Program built in character generator</p>
4	X	<p>Output X. This sequence allows you to send char 0-x with out triggering other commands.</p> <p>Examples:</p> <p>SmartModule</p> <p>serout 13,4,0,4,1 or hserout 4,0,4,1</p> <p>Atom</p> <p>serout 13,i9600,[4,0,4,1]</p> <p>Stamp</p> <p>serout 13,84,[4,0,4,1]</p> <p>Sends the raw characters 0 and 1 to the display</p>

5	0	No splash message This command is only valid when the LCD is in program mode.
5	1-7	Saves the baud rate for the next time the LCD is started. 1:1200 2:2400 3:9600 4:19200 5:38400 6:57600 7:115200 Examples: SmartModule serout 13,5,41 or hserout 5,4 Atom serout 13,i9600,[5,4] Stamp serout 13,84,[5,4] Sets the baud rate to 19200 then next time the LCD is started in normal mode. This command is only valid when in program mode. Bring pin 4 low at startup.
5	8-253	Sets the amount of time the splash messages is displayed on screen at startup or when the LCD is reset. The Value sent is multiplied by 8 and is in milliseconds. For example 100 will display the splash message for 800 ms. Examples: SmartModule serout 13,5,250 or hserout 5,250 Atom serout 13,i9600,[5,250] Stamp serout 13,84,[5,250] This will cause the startup splash message to delay for 2000ms (2 Seconds) This command is only valid when the LCD is in program mode.
5	254	Don't erase splash screen. This command is only valid when the LCD is in program mode.
5	255	Don't display baud setting. This command is only valid when the LCD is in program mode.

6	X Y Z ...	<p>Sets the splash message when the LCD is started. Once in this mode you must send 16 characters or end it by sending a 0.</p> <p>Examples:</p> <p>SmartModule</p> <pre>serout 13,6,"My First LCD" or hserout 6, "My First LCD"</pre> <p>Atom</p> <pre>serout 13,i9600,[6, "My First LCD"]</pre> <p>Stamp</p> <pre>serout 13,84,[6, "My First LCD"]</pre> <p>Will display the message 'My First LCD' each time the LCD is started.</p> <p>This command is only valid when the LCD is in program mode.</p>
7	1 x	<p>Set character delay for LCD. Default is 60.</p> <p>This command is only valid when the LCD is in program mode.</p>
7	2 x	<p>Set control delay for LCD. Default is 14. This is milliseconds</p> <p>This command is only valid when the LCD is in program mode.</p>
7	3 x	<p>The delay in milliseconds x 4 to allow the LCD to power up. Default is 100.</p> <p>This command is only valid when the LCD is in program mode.</p>
7	4 x	<p>Max debug length. This is the wrap point for the LCD. Default is 15. If you have a 20 character display use 19.</p> <p>This command is only valid when the LCD is in program mode.</p>
7	5 0	<p>Disable Clear while in debug mode. Default.</p> <p>This command is only valid when the LCD is in program mode.</p>
7	5 1	<p>Enable Clear while in debug. When the program lead (pin 4) is forced low the LCD will clear while in debug mode.</p> <p>This command is only valid when the LCD is in program mode.</p>
7	6 0	<p>Disable Debug on next restart (non program mode)</p> <p>This command is only valid when the LCD is in program mode.</p>
7	6 1	<p>Enter debug mode on next restart (non program mode)</p> <p>This command is only valid when the LCD is in program mode.</p>
8	1 99	Init LCD
8	1 99	Restart LCD (Same as Power Up)
All Others		Sends the character to the LCD display.

Programming the Serial LCD

By default the LCD is in normal operating mode. To place the LCD into program mode just drive pin 4 low by connecting it to pin 1 as shown in the following schematic. Note you must restart the LCD to enter program mode.

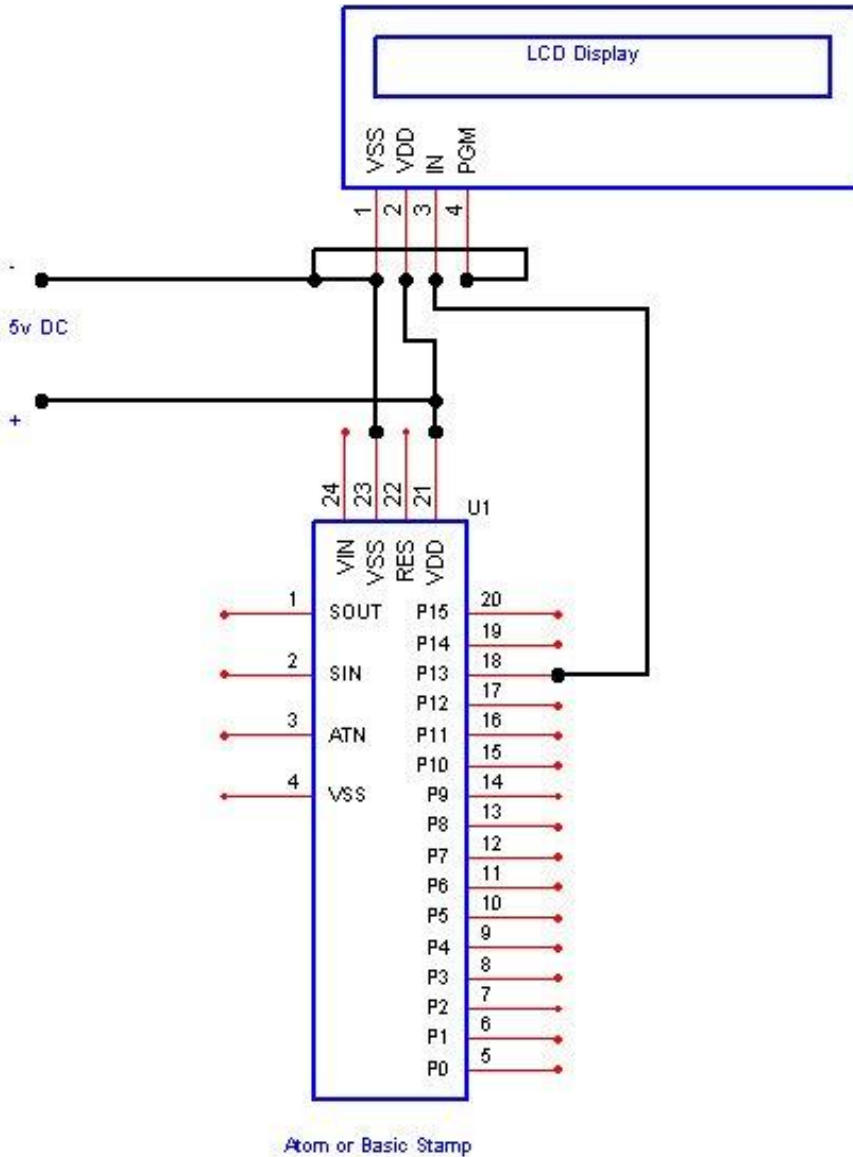

The following parameters may be modified while in program mode.

- Baud Rate
- Splash Messages
- Splash Delay
- Timing and debug options

The LCD will still operate but the baud rate will be fixed at 9600 and the commands 5-6 can now be used to program the above parameters.

Once the connection between pin 4 and 1 is broken and the LCD is restarted the saved parameters will become active including any baud rate changes.

This may seem a bit complicated but it allows the user to reset the LCD back to its original settings by issuing the following command while in program mode.

When you are not in program mode just leave pin 4 floating.

```
serout pin,i9600,[5,3,5,255,6,"Kronos LCD v1.3 "]
```

Please note that program mode does not need to be used at all. It's only there for advanced or OEM users to change the above parameters.

Links

Be sure to visit the Kronos Robotics web site for more information and updates. You can also download example programs for various processors for the serial LCD.

Web Site

<http://www.kronosrobotics.com>

Full color assembly instructions and other downloads

<http://www.kronosrobotics.com/products/pdfs/pdfs.htm>